

# Myriad™ Kit B

Flat Base

**\*Before You begin assembly, please locate and ID all parts listed.**

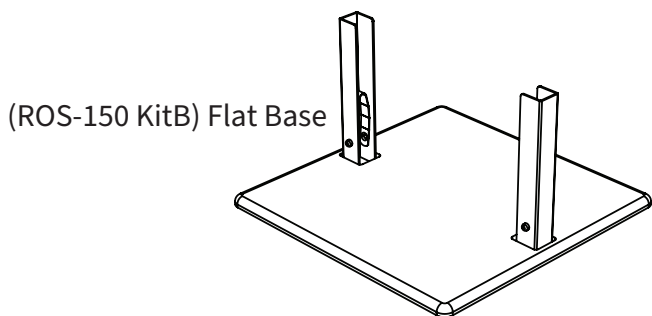

(ROS-150 Kit C)  
Upper Frame  
for ref. only

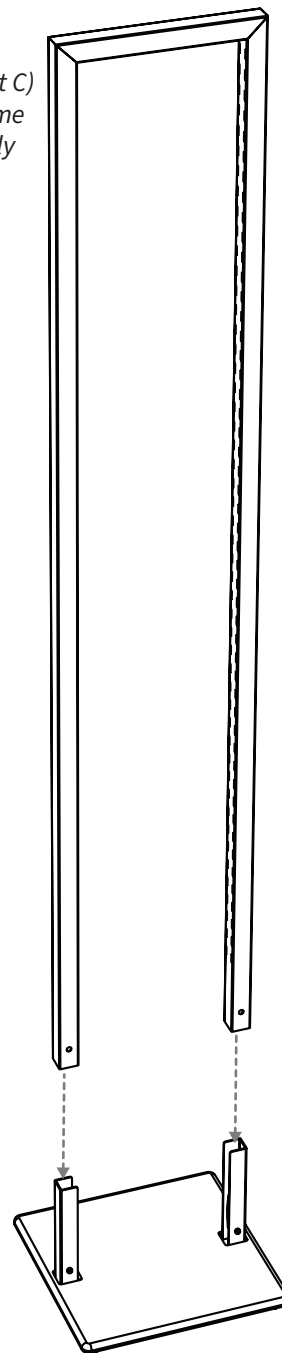

**Detail 2**

**1**

Please Note: The Kit B (Base) ships fully assembled. The following is instructions to attach it to kit C (Frame).

Slip the upper frame (Kit C) over the posts on the base. With one hand at each of the frame bottoms, press the locking features and slide the frame completely onto the base. Frame is connected securely when you hear clicks at both frame bottoms. **(Detail 1)** \*Be careful not to pinch fingers between the frame and base.

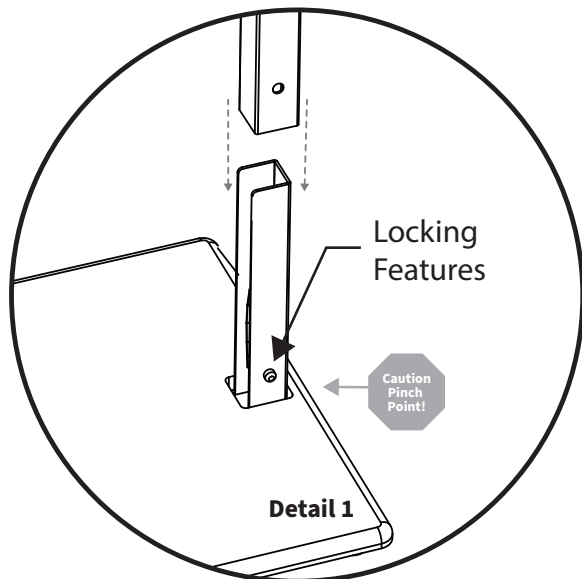

**2**

Refer to the instruction sheet included with the merchandising accessory kit along with your store planogram for merchandising setup and product layout.

99ROS150KITB

Myriad™ is a trademark of Rose Displays, Ltd. Neither the manufacturer nor any sales agent may be held liable for injury, loss or damage resulting from the use of these products.

500 Narragansett Park Drive Pawtucket, RI 02861 | 800.631.9707 | www.rosedisplays.com | signware@rosedisplays.com

**rose** displays  
The Signware™ Specialists